

## AC-43 / AC-42 / AC-41 Force Balance Accelerometer

### Features

- Full Scale:  $\pm 2$  g ( $\pm 0.625$ , 1, 4, 5 g optional)
- Bandwidth DC to 100 Hz
- MEMS Force Balance Accelerometer
- High accelerations measurement
- High shock survivability
- Large temperature range
- High lifetime stability
- Cost effective sensor
- Low power consumption
- Simple test and calibration
- Single Bolt Mounted Enclosure provides up to  $\pm 10^\circ$  of Leveling Adjustment



### Outline

The AC-43 sensor package is a triaxial accelerometer designed for urban and industrial applications regarding strong motion earthquake survey and vibration monitoring as well as alarm and switch systems.

All these applications require rugged sensors with minimum maintenance and a simple method for periodic testing.

The AC-43 accelerometer is based on the modern MEMS (Micro Electro-Mechanical Systems) technology, consisting of sensing cells assembled in a way that optimizes their performances. This combined with the state of the art proprietary circuit design yields this cost effective and reliable accelerometer.

MEMS cells include linear accelerometer sensing elements which measure the capacitance variation in response to any movement or inclination and a factory trimmed interface chip that converts the capacitance variations into analog or digital signal proportional to the motion.

The DC response allows the sensor to be easily repaired, tilt tested or recalibrated in the field. With the help of the TEST LINE the AC-43 accelerometer can be completely tested assuring proper operation.

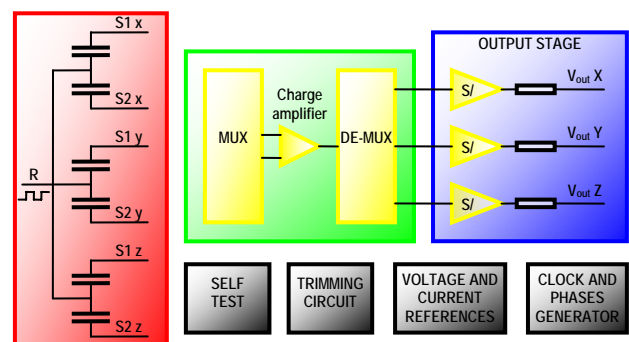

The AC-43 is typically housed in the standard GeoSIG sealed cast aluminium housing with dimensions of 195 x 112 x 96 mm. The housing also incorporates a single bolt mount with three levelling screws. Stainless steel packaging options are available.

The AC-4x accelerometer is directly compatible with the GeoSIG recorders. It is also designed to be mounted internally in standard GeoSIG recorders.

# Specifications AC-43 / AC-42 / AC-41 Force Balance Accelerometer

## General Characteristics

Application: - Strong-Motion earthquake recording  
 - Vibration monitoring  
 - Alarm / Switch systems

## Configurations:

AC-43 or AC-43i\*:

AC-42-H or AC-42-Hi\*:

AC-42-V or AC-42-Vi\*:

AC-41-H or AC-41-Hi\*:

AC-41-V or AC-41-Vi\*:

	Triaxial	Biaxial	Uniaxial	Axes	Alignment**
AC-43 or AC-43i*	■			X - Y - Z	H - H - V
AC-42-H or AC-42-Hi*		■		X - Y	H - H
AC-42-V or AC-42-Vi*			■	X (or Y) - Z	H - V
AC-41-H or AC-41-Hi*				X (or Y)	H
AC-41-V or AC-41-Vi*			■	Z	V

\* i : Internal sensor \*\* H: Horizontal, V: Vertical

Full Scale Range:  $\pm 2$  g Std  
 Optional  $\pm 0.625, \pm 1, \pm 4$  or  $\pm 5$  g

## Sensor Element

Type: MEMS Force Balance Accelerometer  
 Dynamic Range: 90 dB at 2 g FS (0.1 to 30 Hz)  
 97 dB at 5 g FS  
 AC-43-24: > 100 dB at 2 g FS  
 Noise: 150  $\mu\text{g}_{\text{RMS}}$   
 Nonlinearity: < 0.3 % typ., < 0.6 % for vertical  
 Cross Axis Sensitivity: < 2 % typ.  
 Bandwidth: DC to 100 Hz  
 Span drift: 100 ppm/ $^{\circ}\text{C}$   
 Offset Drift:  $\pm 0.8$  mg /  $^{\circ}\text{C}$   
 Full Scale Output: 0  $\pm 10$  V differential (20 Vpp)  
 optional 2.5  $\pm 2.5$  V single-end (5 Vpp)  
 0 to 20 mA current loop

## Measuring Range:

See plot

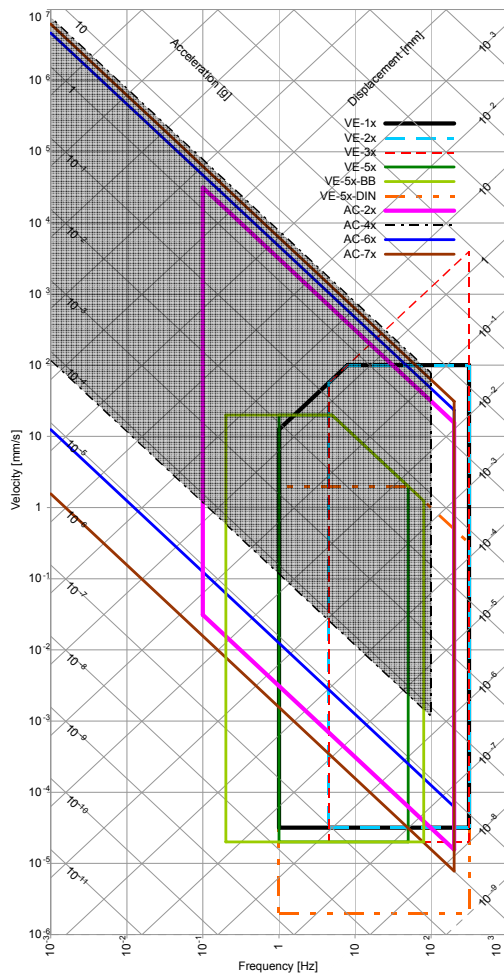

## Power

Supply Voltage: 7 to 15 VDC, single supply  
 optional, 7 to 30 VDC  
 Consumption: 9 mA @12 VDC  
 Connector: Metallic, Shielded, IP67, 12 pins, male  
 optional MIL, Bendix PT07A 14-19P  
 Binder / Coninvers type RC  
 All pins are protected

## Connector Pin Configuration

Pin 1-6: Signal output for axis X, Y, Z  
 Pin 7,8: Test Input  
 Pin 9-10: + 12 VDC power supply  
 Pin 11-12: Not used  
 Case: Shielded Ground

## Environment/Housing

Housing Type: Cast aluminium  
 Sealed access cover  
 Housing Size: 195 x 112 x 96 mm  
 Weight: 2.0 kg  
 Index of Protection: IP 65  
 optional IP68  
 Temperature Range: - 40 to 85  $^{\circ}\text{C}$  (operating)  
 - 40 to 85  $^{\circ}\text{C}$  (non-operating)  
 Humidity: 0 to 100 % (non-condensing)  
 Orientation: Can be configured for mounting in any position.  
 Mounting: Single bolt, surface mount, adjustable  
 within  $\pm 10^{\circ}$

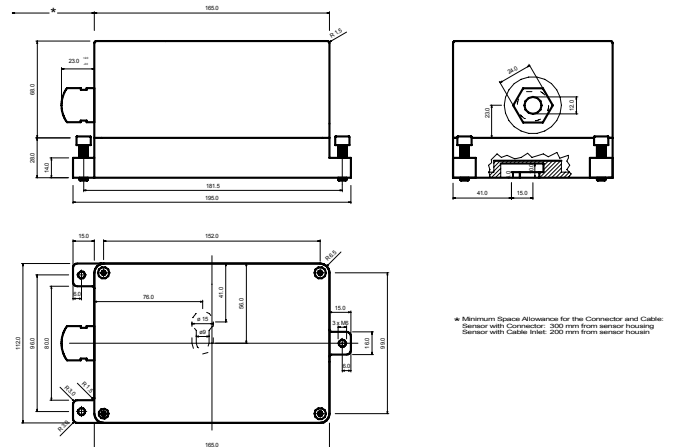

## Standard AC-4x

Floor mounted, Full scale  $\pm 2$  g,  
 2 m cable with cable inlet and recorder  
 mating connector, concrete anchor bolt  
 and user manual on CD

## Options

Cable & connector: Cable connector  
 Metallic, Shielded, IP67, 12 pins, male  
 optional MIL, Bendix PT07A 14-19P  
 Cable with shielded twisted pairs for any  
 length (including mating sensor  
 connector) with open end  
 Cables for connection to GeoSIG  
 recorder  
 Connector on user specification mounted  
 at cable end  
 Housing: Watertight IP 68 housing  
 Downhole housing (AC-4x-DH)  
 Stainless steel protective housing  
 As internal sensor  
 Mounting: Wall mounted